



徐工徐工 助您成功
XCMG FOR YOUR SUCCESS

XE950G/XE950GA/XE950DA 矿用挖掘机 XE950G/XE950GA/XE950DA MINING HYDRAULIC EXCAVATOR



- 铲斗容量 Bucket Capacity (m³) : 4.6-7.0
- 操作重量 Operation Weight (kg) : 91000
- 额定功率 Output power (kW/rpm) : 447-447.5/2000-2100



WWW.CAMCVIAL.COM.AR

更节能环保

More energy-conservation and environmental protection



- XE950G/XE950GA:

采用原装进口珀金斯 (2806J/2806EA) 电控、直喷、4冲程、水冷、涡轮增压、空空中冷、六缸大扭矩低转速发动机。

该发动机具有高可靠性、高适应性的优点，排放达到中国IV阶段、北美Tier4F、欧洲StageV阶段标准，是专门针对工程机械作业工况精心设计制造的产品。

XE950G/XE950GA:

It adopts imported Perkins (2806J/2806EA) electronic control, direct injection, 4-stroke, water cooling, turbocharging, air-to-air intercooling and six-cylinder high-torque low-speed engine.

The engine has the advantages of high reliability and high adaptability. Its emission meets the standards of China's Stage IV, North America Tier 4F and European Stage V. It is specially designed and manufactured for the working conditions of construction machinery.

- XE950DA:

采用原装进口珀金斯 (2806D) 电控、直喷、4冲程、水冷、涡轮增压、空空中冷、六缸大扭矩低转速发动机。该发动机具有高可靠性、高适应性的优点，排放达到中国三阶段、北美Tier3、欧洲StageIII A阶段标准，是专门针对工程机械作业工况精心设计制造的产品。

"XE950DA:

It adopts imported Perkins (2806D) electronic control, direct injection, 4-stroke, water cooling, turbocharging, air-to-air intercooling and six-cylinder high-torque low-speed engine

The engine has the advantages of high reliability and high adaptability. Its emission meets the standards of China's Stage III, North America Tier 3 and European Stage V. It is specially designed and manufactured for the working conditions of construction machinery."

- 采用正流量电控系统，精确控制各种作业动作，降低油耗；

Adopt positive flow electric control system to control all kinds of operation action accurately and reduce fuel consumption;

更高效回报

More efficient return

- 标配6.0m³重载铲斗，具有更高的作业效率；

The standard 6.0m³ heavy-duty bucket has higher operating efficiency;

- 大扭矩、大排量发动机，高压液压系统，更能胜任矿区的重载作业工况；

Large torque, large displacement engine and high pressure hydraulic system are more competent for heavy load operation in mining area;

- 自主知识产权XEICS系统，精确调试液压、动力匹配性，提高12%作业效率。

XEICS system with independent intellectual property rights can accurately debug the hydraulic and power matching, and improve the operation efficiency by 12%.

更可靠耐用

More reliable and durable

- 泵、阀、马达关键液压元件寿命达3万小时；
The service life of key hydraulic components such as pumps, valves and motors can reach 30000 hours;
- 选装防爆阀，防止管路破损造成工作装置突然下降，使安全性得到加强。
The optional explosion-proof valve can prevent the working device from falling suddenly due to the damage of the pipeline, so that the safety is enhanced.
- 采用矿用型发动机，强化缸体、凸轮轴、曲轴及连杆，大幅延长大修时间；适应中国市场的电控单体泵燃油系统，大大降低发动机故障率；提高防尘能力，大幅降低电气件故障及发动机拉缸风险。
The use of mining engines, reinforced cylinder block, camshaft, crankshaft and connecting rod, greatly extend the overhaul time; the electronically controlled unit pump fuel system adapted to the Chinese market greatly reduces the engine failure rate, improves the dust-proof ability and greatly reduces the risk of electrical parts failure and engine cylinder scratching.
- 关键液压元器件优化配过，采用更大通径的主阀，一体式输出机构的回转减速机和更大规格的行走减速机，使机器获得更大的液压能、更大的回转和行走驱动力，更适合恶劣的矿山施工。
The key hydraulic components have been optimized. It uses larger diameter main valve, rotary reducer with an integrated output mechanism and a larger walking reducer, so that the machine can obtain greater hydraulic energy, greater rotary and walking driving force, more suitable for harsh mine construction.



- 回转平台、动臂、斗杆增加薄弱处板厚，比上代产品提高承载能力50%，并大大提升抗弯截面模量；全新设计的结构件，经过CAE设计分析，并通边苛刻的冲击实测，平均应力较上代产品降低30%；下车四轮一带，加强纵梁、H架承载能力，加强履带链轨、支重轮等，提升承载能力30%。
The thickness of the weak parts of the rotary platform, boom and bucket rod is increased, the bearing capacity is increased by 50% compared with the previous generation products, and the bending section modulus is greatly improved; the average stress of the newly designed structural parts is reduced by 30% compared with the previous generation products after CAE design analysis and rigorous impact measurement; the four-wheel one-belt of the vehicle is used to strengthen the bearing capacity of longitudinal beam and H-frame, strengthen the caterpillar, support roller, etc., and increase the load-bearing capacity by 30%.

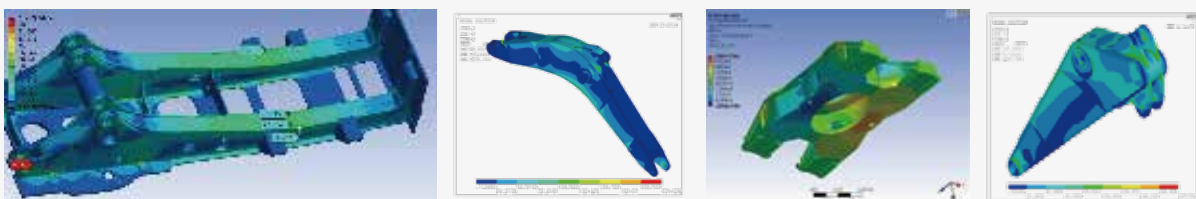

- 先进的XEICS徐工挖机智能管理系统，采用CAN总线通讯和物联网技术，集主控制系统、发动机ECM、监控系统、操控面板、GPS云控系统和现场诊断系统，实现机器信息数字化共享，提高产品智能化水平。便捷的手机APP微服务，随时随地掌握挖机的位置、作业状况、工作时间、燃油消耗、保养周期。

The advanced XEICS XCMG excavator intelligent management system adopts CAN bus communication and Internet of Things technology, integrates the main control system, engine ECM, monitoring system, control panel, GPS cloud control system and field diagnosis system to realize digital sharing of machine information and improve the intelligent level of products. Convenient mobile APP micro-service can grasp the location, operation status, working time, fuel consumption and maintenance cycle of excavator anytime and anywhere.

- 故障代码全解析：所有故障代码全部自动解析，故障内容一目了然，彻底抛弃查询手册的繁琐；
Full analysis of fault code: all fault codes are automatically parsed, the fault content is clear at a glance, and the tedious query manual is completely abandoned;
- 附件管理系统：借助该系统，操作手可通过驾驶室内的监控器预先选定所需模式，以确保各种附件的可用性。
Accessory management system: with this system, the operator can pre-select the required mode through the monitor in the cab to ensure the availability of various accessories.
- 丰富的操作模式：除了标准的ISO反铲操作模式，允许用户自定义操作模式，满足不同用户的操作习惯；
Rich operation modes: in addition to the standard ISO backhoe operation mode, the user can customize the operation mode to meet the operation habits of different users;
- 附加功能更丰富：风扇反转除尘，后视影像，保养提醒等实用功能。
Additional functions are more abundant: reverse dust removal fan, rear view image, maintenance reminder and other practical functions.

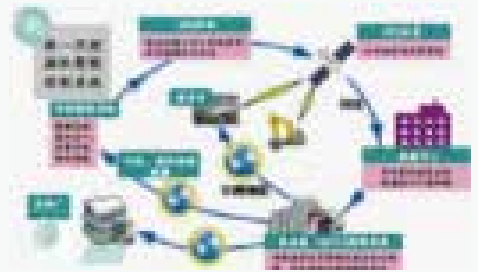

更智能管控 More intelligent management and control

- 自主控制器采集车辆位置的海拔离度和发动机进气压力，自动判定确定数据库，在显示器上提示操作者选择高原模式。智能匹配液压泵与发动机功率，从而保证泵的流量输出，降低发动机掉速比，防止冒黑烟和憋车，保证挖掘机工作效率。

The autonomous controller collects the altitude of vehicle position and engine intake pressure, automatically determines the database, and prompts the operator to select plateau mode on the display. It can intelligently match the power of the hydraulic pump and the engine, so as to ensure the flow output of the pump, reduce the engine speed drop ratio, prevent black smoke and engine stall, and ensure the working efficiency of the excavator.

- 可智能实现远程无人驾驶：基于5G实现高速率、低延时，打破时空限制，还原真实场景，实现矿用液压挖掘机远程操控。

It can intelligently realize remote unmanned driving: Based on 5G, it can realize high-speed and low delay, break the limitation of time and space, restore the real scene, and realize the remote control of mining hydraulic excavator.



更舒适安全

More comfortable and safe

- 针对矿山作业工作时间长、振动量大的特点，选用空气悬浮座椅，扶手与座椅同步高度调整，降低驾驶员的疲劳度，提高舒适性。

According to the characteristics of long working time and large vibration in mine operation, air suspension seat is selected. By adjusting the synchronous height of armrest and seat, the driver's fatigue is reduced and the comfort is improved.



- 驾驶室采用全新设计的正压驾驶室，密封性较上代产品提高70%，有效隔离灰尘，大幅降低驾驶室内噪音，同时扩大了驾驶室的空间，提高舒适性。

The cab adopts a newly designed positive pressure cab, the sealing performance is improved by 70% compared with the previous generation. It can effectively isolate dust and greatly reduce the noise in the cab. At the same time, it expands the space of the cab and improves comfort.



- 针对矿山工况，采用强化驾驶室，安全性比普通驾驶室提高35%，标配后视摄像头、报警灯、顶防护网、前防护网、急停开关、维修照明灯等，选配360°全景影像，进一步提高设备矿山作业的安全性。

In view of the mine working conditions, the safety of the strengthened cab is 35% higher than that of the ordinary cab. The standard rear-view camera, alarm light, top protection net, front protection net, emergency stop switch, maintenance lamp, etc., and 360° panoramic image are selected to further improve the safety of mining operation.



便捷的维护保养

Convenient repair and maintenance

- 中部检修通道，可以提供更方便的维护保养；
The central maintenance channel can provide more convenient maintenance;



- 可以通过左、右侧通道直接进入散热器舱、空滤舱、泵室进行检查；
You can directly enter the radiator compartment, air filter compartment, and pump room through the left and right channels for inspection;

- 集中保养设计更加方便维护保养；
Centralized maintenance design is more convenient for maintenance;



- 触手可及的加注口，更加方便维护保养。
The easily accessible filling port is more convenient for maintenance.

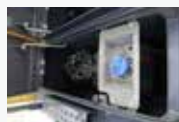

铲斗配置

Configuration of bucket

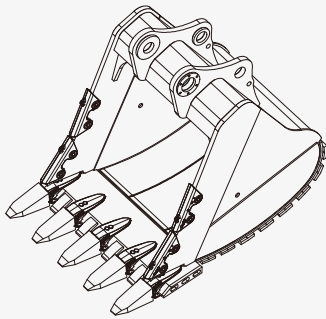

5.4m³

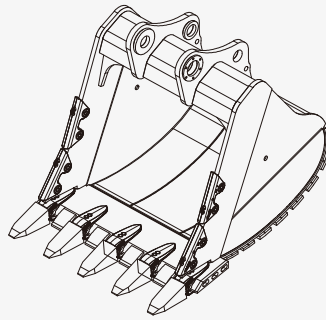

6.0m³

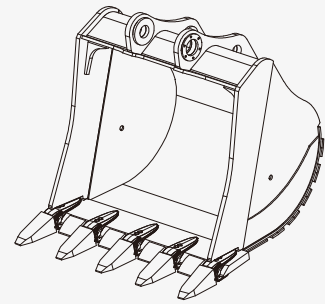

6.5m³

铲斗配置表 Configuration of bucket

XE950G/GA/DA

铲斗类型 Bucket type	铲斗容量 Bucket capacity	填充率 Filling rate	动臂 Boom: 7250 mm	底盘类型 Chassis type
	m ³	%	斗杆 Bucket rod: 2925 mm	
轻载挖掘 Light load excavation	7.0	100	○	加长型底盘 Extended chassis
普通挖掘 Common excavation	6.5	100	⊙	加长型底盘 Extended chassis
	6.0 (标配)	90	□	加长型底盘 Extended chassis
重载挖掘 Heavy load excavation	5.4	90	□	加长型底盘 Extended chassis
	4.6	90	■	加长型底盘 Extended chassis

- : 适用于密度小于2100 kg/m³或以下物料 Suitable for the material which density is less than 2100kg/m³
- : 适用于密度小于1800 kg/m³或以下物料 Suitable for the material which density is less than 1800kg/m³
- ⊙: 适用于密度小于1500 kg/m³或以下物料 Suitable for the material which density is less than 1500kg/m³
- : 适用于密度小于1200 kg/m³或以下物料 Suitable for the material which density is less than 1200kg/m³
- △: 适用于密度小于 900 kg/m³或以下物料 Suitable for the material which density is less than 900kg/m³

定制化 Customization

标准配置 Standard configuration		XE950G/GA/DA
发动机 Engine 发动机型号 Model of engine: 2806D/2806EA/2806J 排放等级 Emission level: 国三/国四/欧V 带水位指示传感器的油水分离器 Oil-water separator with water level indication sensor 径向密封空气滤清器 Radial seal air filter 50° C高温环境冷却组件 Cooling components of 50° C high temperature environment 散热器防尘网 Dust screen of radiator 燃油油标 Fuel leveler 带反吹功能的独立散热模块 Independent cooling module with reverse blow function 机油快速加注系统 Quick oil filling system 机油油品质取样 Oil sampling 防冻液取样 Antifreeze sampling DEF远程加注 DEF Remote filling 燃油呼吸阀 Fuel breather valve 空气压差指示器 Air differential pressure indicator 自动怠速 Automatic idle speed	驾驶室与内饰 Cab and interior trimming 增压驾驶室 Pressurized cab 完全可调的空气悬浮座椅 Completely adjustable air suspension seat 可调节座位扶手 Adjustable armrest 安全带 (51 mm [2"] 宽) Safety belt (51 mm [2"] width) 配备辅助装置的可开启前挡风玻璃 Openable front windshield glass equipped with auxiliary equipment 按 70/30 比例分割的前挡风玻璃 Front windshield window cut with ratio of 70/30 双层夹胶挡风玻璃和其他钢化窗户 Double-layer laminated windshield and other tempered Windows 可滑动的车门上窗 Slidable upper window of door 带除霜器的双向出风空调 (自动型) (加压功能) Double-way air-out air conditioner with defroster(automatic)(pressurized) 可显示警告信息、滤清器/液体更换信息和工小时数的彩色液晶显示屏 Color LCD display with data of alarm, filter/fluid change and working hours 操纵手柄 Control handle 装有可拆卸手动操纵杆的行驶控制踏板 Travel control pedal with removable manual control lever 两个立体声扬声器 Two stereo speakers 饮料杯架 Beverage holder 衣帽钩 Coat and hat hook 可清洗地板垫 Washable floor mat 空调系统 Air conditioner system 高低速换挡 High/low speed shift gears 遮阳帘 Shade curtain 顶部天窗 Top skylight 雨刮器 wiper 杯架/文件袋 Cup holder/file packet 冷暖储物箱 Heating and cooling storage box 无线收音机 Wireless radio	安全与保安配置 Safety and security configuration 驾驶室门锁和各舱室锁 Door lock of cab and chambers 警报喇叭 Alarm horn 发动机和油泵室之间的隔离板 Spacer plate between engine and oil pump chamber 发动机紧急停机开关 Emergency stop switch of engine 后窗紧急出口 Emergency exit of rear window 蓄电池断开开关 Shutdown switch of battery 动臂、斗杆保持阀 Holding valve of boom and arm 过热报警 Overheat alarm 安全扶手和踏板 Safety rail and pedal 旋转报警灯 Rotating alarm light 防滑板/防滑垫 Anti-skid plate/anti-slip tip 液压安全锁定杆 Hydraulic safety lock lever 紧急逃生锤 Emergency escape hammer 左右后视镜 Left and right rearview mirror 后视监控摄像头 Rearview monitor camera 落物防护结构 (FOPS) Fall Off Protection Structure(FOPS)
液压系统 Hydraulic system 动臂/斗杆流量再生 Boom/arm flow regeneration 反向回转阻尼阀 Reverse rotary damping valve 自动回转停车制动器 Automatic rotary parking brake 直行液压回路 Travel straight hydraulic circuits 动臂优先阀 Boom priority valve 回转逻辑阀 Rotary logic valve 液压油 ISO VG 46 Hydraulic oil ISO VG 46 回转减速机齿轮油油品质取样 Gear oil sampling of rotary reducer 液压油油品质取样 Hydraulic oil sampling 液压油快速加注系统 Hydraulic oil quick filling system 操作方式切换 Operating modes switch 回转防摇摆阀 Rotary anti-sway valve 备用阀片 Spare valve disc 仪表压力监控 Instrument pressure monitor	底盘系统与护罩 Chassis sytem and protective guard 底架牵引环 Underframe bail 保护装置套件: 底盘底部封板、行走马达封板 Protection suite: close plate at the bottom of chassis, close plate of travel motor 650 mm (24") 双筋履带板 650 mm (24") Double rib track plate 加长底盘 Extended chassis 全长度履带护轨器 Overall length crawler guardrail device	电气系统 Electrical system 蓄电池 (4 × 950 CCA) Battery (4 × 950 CCA) 95 A 直流发电机 95 A Alternator 9.5 kW 启动马达 9.5 kW start motor 行走报警器 Travel alarm 摄像头 Camera 5V USB接口 5V USB interface 12/24V电源接口 12/24V Power interface
工作装置 Working device 动臂 7.25m Boom 7.25m 斗杆 2.925m Arm 2.925m 铲斗6.0 m³加强斗 Bucket 6.0m³ Strengthen Bucket	配重 Counterweight 12.4 t 配重 12.4t Counterweight	照明灯 Lamp 左右两侧动臂工作灯 Boom working lamp at left and right side 安装在储物箱上的右侧工作灯 Working lamp installed on the right side of storage box 驾驶室内部照明 Lamp inside the cab 驾驶室顶安装的前工作灯 Front working lamp installed on the top of cab 驾驶室顶安装的后工作灯 Rear working lamp installed on the top of cab
选装配置 Optional configuration	技术 Technology XEICS智能控制系统 XEICS intelligent control system 数据链路插座 Data link socket	润滑系统 Lubrication system 电动单线式自润滑系统 Electric single line self lubricating system
带加热器油水分离器 (24V) Oil-water separator with heater (24V) 油水快放装置 Oil and water quick discharge device 冷却液加热器 (燃油式) Coolant heater(fuel type) 燃油加油泵 50L/min Fuel refueling pump 50L/min 燃油快速加注系统 Fast fill fuel system OCV (开放式曲轴箱通风) 过滤器 OCV (open crankcase ventilation) filter 水套加热系统 Jacket heating system 辅助液压阀 Auxiliary hydraulic valve 液压缓冲阀 Hydraulic buffering valve 液压管路: 破碎锤 Hydraulic line: quartering hammer 液压管路: 拇指钳及油缸 Hydraulic line: thumb pliers and cylinder 液压管路: 防爆阀管路及油缸 Hydraulic line:pipeline of explosion-proof valve and cylinder 液压管路: 快速连接器 Hydraulic pipeline:quick connector	液压管路: 液压剪 Hydraulic line:hydraulic shear 液压管路: 液压振动夯/高频破碎器 Hydraulic line:hydraulic vibration rammer/high-frequency breaker 液压管路: 液压抓具 Hydraulic line:hydraulic grapple 操作方式切换 Operating modes switch 液压油 ISO VG 32 ,68 Hydraulic oil ISO VG 32 ,68 灭火器 Fire extinguisher 一键增压模式 Onekey boost mode 工作辅具预留开关 Reserved switch for auxiliary equipment 动臂、斗杆管路防爆阀 Explosion-proof valve of boom and arm pipeline 750 mm (28") 双筋履带板 750 mm (28") Double rib track plate 900 mm (31") 双筋履带板 900 mm (31") Double rib track plate 斗杆 3.4m Arm 3.4m 铲斗4.6 m³岩石斗 Bucket 4.6m³ Rock bucket 铲斗5.4 m³岩石斗 Bucket 5.4m³ Rock bucket	铲斗6.5 m³加强斗 Bucket 6.5m³ Strengthen Bucket 铲斗7.0 m³土方斗 Bucket 7.0 m³ Earth working bucket 快速连接器 Quick connector 破碎锤 Quartering hammer 液压拇指钳 Hydraulic thumb pliers 松土器 Scarifier 振动夯 Vibrating tamper 液压剪 Hydraulic shear 抓具 Grip 高频破碎器 High frequency breaker 贝壳斗 Clam shell bucket 梅花抓斗 Plum-blossom shape grab bucket 筛型斗 Screen-type bucket 岩石臂 Strengthen rock boom 手动润滑 Arm concentration

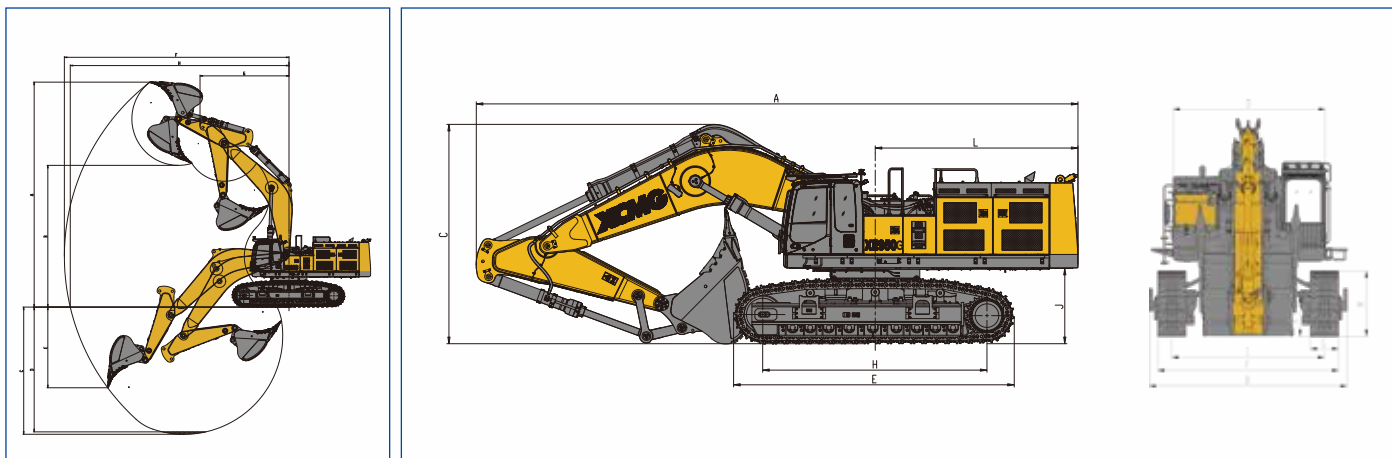

主要参数 / Main Specifications

型号 Model	单位 UOM	参数 Parameters
操作重量 Operation Weight	kg	91000
铲斗容量 Bucket Capacity	m ³	6
动臂 Boom	mm	7250
斗杆 Arm	mm	2925

发动机 Engine

发动机型号 Model	/	2806J/EA/D
直喷 Direct injection	/	√
4冲程 Four strokes	/	√
水冷 Water cooling	/	√
涡轮增压 Turbo-charging	/	√
空中中冷 Air to air intercooler	/	√
缸数 No. of cylinders	/	6
额定输出功率/转速 Output power	kW/rpm	447/200(XE950G/GA) 447.5/2100(XE950DA)
最大扭矩/转速 Torque/speed	N.m/rpm	2811/1300(XE950G/GA) 2742/1400(XE950DA)
排量 Displacement	L	18.1

主要性能 Main performance

行驶速度(高/低) Travel speed (H/L)	km/h	4.0/2.4
回转速度 Rotating speed	r/min	6.2
爬坡能力 Gradeability	°	35
接地比压 Ground pressure	kPa	124
铲斗挖掘力 Bucket digging force	kN	463
斗杆挖掘力 Arm digging force	kN	370
最大牵引力 Maximum traction	kN	636

液压系统 Hydraulic system

主泵 Main pump	/	2个柱塞泵 Plunger pumps
主泵额定流量 Rated flow of main pump	L/min	2 × 476
主安全阀压力 Pressure of prime valve	MPa	35
行走系统压力 Pressure of travel system	MPa	35
回转系统压力 Pressure of swing system	MPa	29
先导系统压力 Pressure of pilot system	MPa	3.9

型号 Model	单位 UOM	参数 Parameters
----------	--------	---------------

油类容量 Oil capacity

燃油箱容量 Fuel tank capacity	L	1200
液压油箱容量 Hydraulic tank capacity	L	540
发动机油容量 Engine oil capacity	L	65
冷却液容量 Coolant capacity	L	68
DEF箱容量 Def tank capacity	L	47.2

外形尺寸 Outline dimension

A 总长 Overall length	mm	13655
B 总宽 Overall width	mm	4545
C 总高 Overall height	mm	4980
D 转台宽度 Width of platform	mm	3490
E 履带长度 Length of crawler	mm	6367
F 底盘总宽 Overall width of chassis	mm	4150
G 履带宽度 Width of crawler	mm	650
H 履带轴距 Track length on ground	mm	5090
I 轨距 Crawler gauge	mm	3500
J 配重离地间隙 Clearance under counterweight	mm	1660
K 最低离地间隙 Min. ground clearance	mm	870
L 尾部最小回转半径 Min. tail swing radius	mm	4700
M 履带高度 Height of crawler	mm	1487

作业范围 Working scope

A 最大挖掘高度 Max. digging height	mm	12680
B 最大卸载高度 Max. dumping height	mm	7990
C 最大挖掘深度 Max. digging depth	mm	7170
D 8英尺水平面挖掘深度 Excavation depth of 8 feet level	mm	7030
E 最大垂直挖掘深度 Max. vertical wall digging depth	mm	4550
F 最大挖掘半径 Max. digging reach	mm	12660
G 最小回转半径 Min. swing radius	mm	5020
H 地面最大挖掘半径 Max. ground digging reach	mm	12330

选装配置

动臂长度 Length of boom	mm	/
斗杆长度 Length of arm	mm	3400
铲斗斗容 Bucket capacity	m ³	4.6 (岩石斗 Rock)
	m ³	5.4 (岩石斗 Rock)
	m ³	6.5 (加强斗 Strength)
	m ³	7.0 (土方斗 Soil)

-40℃ 低温配置

-40 °C low temperature configuration

发动机冷却液加热器 Coolant heater

徐州徐工矿业机械有限公司
XUZHOU XCMG MINING MACHINERY CO.,LTD

WWW.CAMCVIAL.COM.AR



CAMC VIAL

Ruta 40 y Calle 7, SAN JUAN - ARGENTINA



(+54-264) 4262275



ARGENTINA

+54-2644998650



info@camcvial.com.ar

材料和规格可随时改变，恕不另行通知
Materials and specifications may be changed at any time without prior notice