



All Rights Reserved

Materials and specifications are subject to change without notice.  
Featured machines in photos may include additional equipment.  
See your XCMG dealer for available options.



# XE75DA

## Hydraulic Excavator



[WWW.CAMCVIAL.COM.AR](http://WWW.CAMCVIAL.COM.AR)



**Advanced Configuration**

**Ecological and economical**

- ▶ Adopting new environmental friendly Yanmar engine, low speed torque, low fuel consumption, high operating efficiency, reliable and durable.
- ▶ The advanced load-sensitive control system, low energy consumption.

**Multiple applications**

- ▶ Short tail design and short slewing radius can achieve flexible operation in confined space
- ▶ Multiple additional configurations to adapt to a variety of operating requirements

**Comfortable operating experience**

- ▶ Fresh air conditioning system to ensure the appropriate temperature
- ▶ Toughened glass cockpit with good safety view
- ▶ Detailed design concept improves comfort

**Excellent after-sales service**

- ▶ Global after-sales service system and quick response mechanism
- ▶ Real-time technical consultation and maintenance

**Convenient maintenance**

- ▶ Easy maintenance design, open the engine hood for no dead angle maintenance
- ▶ The new toolbox is easy to place the commonly used maintenance tools

**The newly optimized working device**

- ▶ Integrated body design
- ▶ Strengthened structure and stress dispersing
- ▶ Upgrade undercarriage to improve load bearing performance



## Ecological And Economical

- ▶ Use of Yanmar naturally aspirated engine widely used in the industry, with the features of small displacement, low fuel consumption, low-speed and large-torque, is perfectly matched the excavator operation conditions. The engine uses direct injection technology with good oil adaptability. The mechanical speed regulation is upgraded to electronic speed regulation, the speed control is more stable, not only reduce the fuel consumption, but also effectively reduce the "black smoke" from the engine.
- ▶ First use of the electronically controlled main pump in the industrial same tonnage product, to control the maximum load torque of the main pump according to the maximum output torque under the different engine speed, which can really achieve the perfect matching the load and power output and greatly improve the engine energy utilization rate.
- ▶ The hydraulic control system uses the advanced load-sensitive control system, low energy consumption, fast response, precise control and small impact. The output flow of the variable piston pump is controlled according to the load feedback signal, which always adapts the requirement of the multi-way valve spool opening, with no more excess flow loss, to achieve load-independent flow distribution, better flexibility for the conformable movement, and easier to achieve ground grading movement.
- ▶ The new generation XE80D bucket capacity is enhanced more 10% than C Series products, the bucket capacity is increased to 0.33m<sup>3</sup>, improving the working efficiency of earthmoving operation.
- ▶ The larger fuel tank capacity, with ultra-low fuel consumption level, extends the machine's continuous operation time.
- ▶ According to the improved and upgraded hydraulic system, the hydraulic tank capacity is re-optimized, which is 11% lower than the C Series products, significantly reducing the machine maintenance costs.

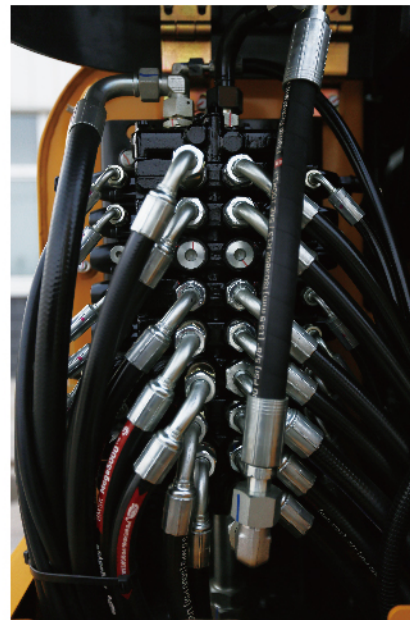
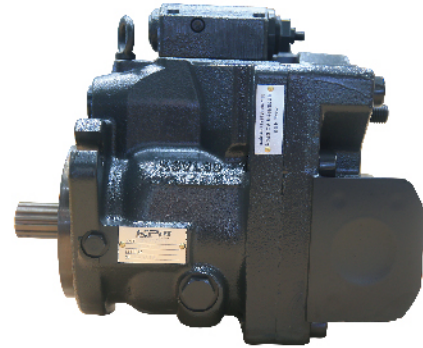

## Comfortable And Reliable

### Comfortable

- ▶ The new spacious and comfortable cab with beautiful appearance, the cab rear column adopts hidden type design with small blind area, which can improve the safety of operation.
- ▶ The standard equipped high-power air-conditioner, with reasonable air conditioning outlet layout. The front window glass has the air conditioning outlet, with a defrost function, which can eliminate fog, so as to ensure the safe driving.
- ▶ The cab is added with ashtray, cup holder, storage box, document folder and backup power jack, which greatly improve the comfort and convenience of the driving.
- ▶ The left door glass of the cab is designed as a sliding window for easy communication.



### Reliable

#### ▶ The newly optimized working device

The position which has larger boom stress is locally strengthened, the arm uses the "U-shaped plate" by compression molding and is welded with upper cover plate, having a longer service life. The standard new type bucket makes the unloading more easily and quickly.

↑  
Bucket capacity  
increased by  
**10%**



#### ▶ Highly reliable rotation platform

The rotation platform main beam adopts the "H-beam" structure, and the side beam adopts "D-shaped section" structure, having higher overall reliability.

#### ▶ Reinforced chassis structure

The chassis structure uses the X-shaped frame, the lower frame is formed a large cross-section box by the stiffener plate, with good load bearing performance, which can apply evenly the superstructure weight on the track beam, reduce the local stress concentration of the track beam. Using international standard reinforced track, which is more reliable and more convenient for maintenance.

- ▶ The new air intake pre-filter, can effectively filtrate the large particles of impurities into the air filter, which extends the service life of air filter.

- ▶ The equipped large Euro-III high-precision rough fuel filter with the oil-water separator, the filtration area is 1.5 times of other same tonnage models.

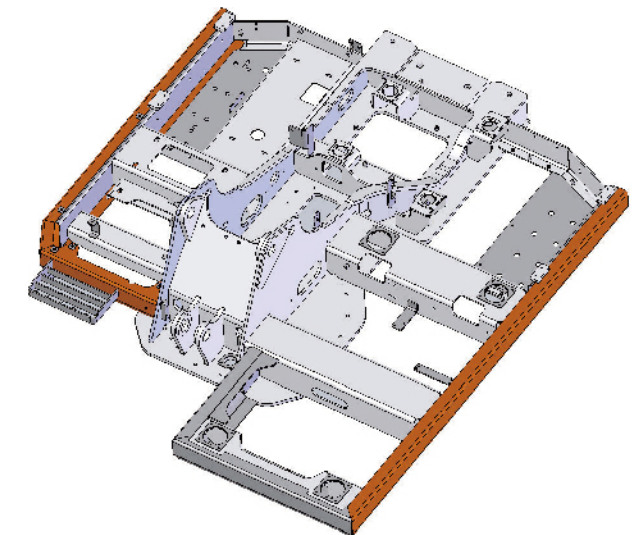
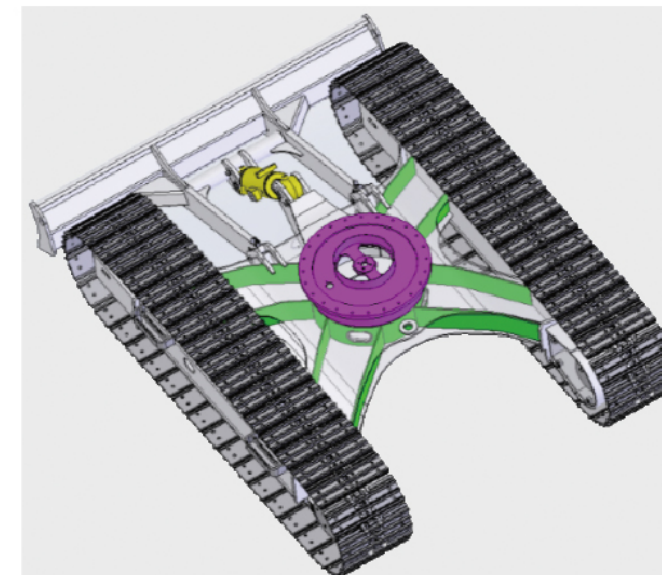

### ▶ Intelligent Control

- ▶ The XEICS system with independent intellectual property rights uses CAN bus communication to realize the corresponding control functions, which can effectively adapt to the working environment, working conditions and workload, so that it will recognize, think, judge, decide, and execute.
- ▶ GPS intelligent cloud control system, linked with the company's CRM, 400, DMS system, integrates GPS positioning function, remote management and remote diagnosis functions, not only can carry the excavator geographical location information, excavator field working parameters and alarm information data upload, It also enables vehicle access management, remote management, remote diagnosis, and remote control.
- ▶ Standard plateau mode function, using GPS positioning technology, can adjust the main pump power according to altitude, prevent engine overload, and achieve electronic energy-saving control.



### ▶ Multiple Application Condition

- ▶ The independently developed multi-functional intelligent work tool control system can meet different operating requirements such as digging, breaking and dismantling, and its working condition adaptability is further strengthened.
- ▶ It is designed with instantaneous boost function, and you can immediately raise the boom speed or the travel traction by pressing this button

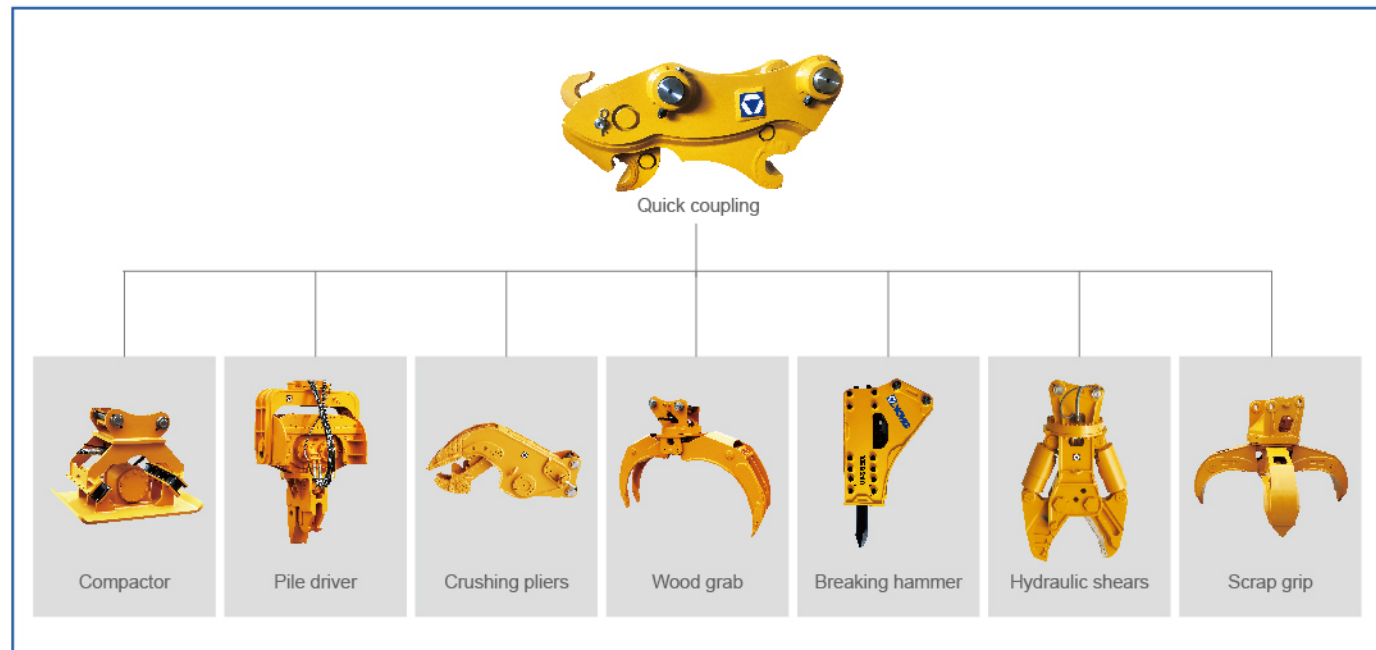

### ▶ Maintenance And Service

- ▶ Accessible maintenance design reduces maintenance time by 10%. Integrate electrical box, air filter, diesel filter, oil filter and pilot filter to make maintenance and replacement convenient.

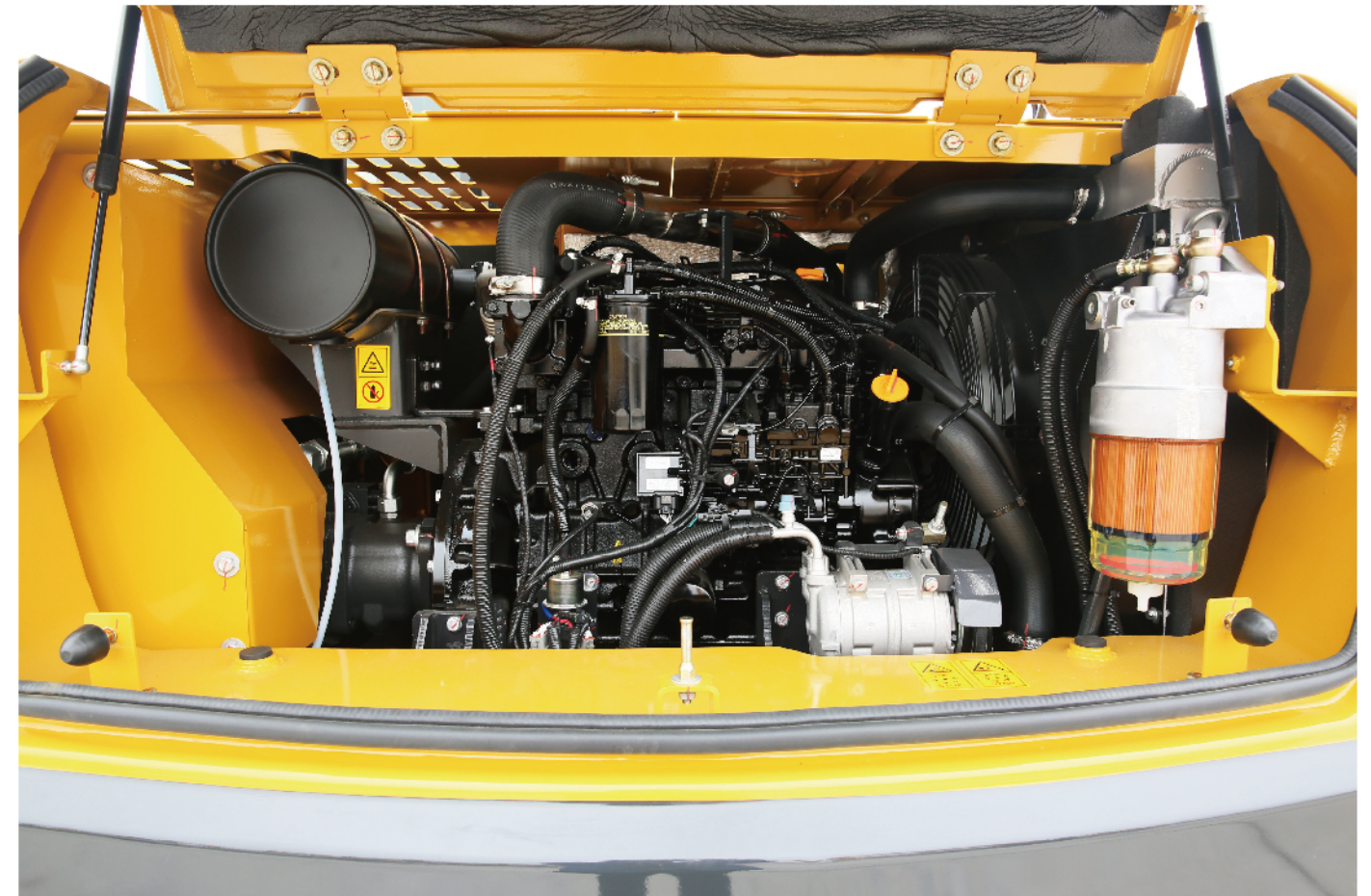

- ▶ The hood is designed with a gas spring-assisted side-up structure and a large opening angle for easy access to the engine and radiator.
- ▶ A protective net is arranged on the outside of the radiator to effectively prevent the inhalation of flying debris and the like, and the disassembly is convenient and the cleaning is easier.
- ▶ A wide range of after-sales service system and quick-response rescue mechanism can ensure that you use machine at ease.

XE75DA hydraulic excavator can be used for digging, loading, ditching, crushing, drilling, clip cutting, lifting and other functions, which has played an increasingly important role in hydropower, transportation, municipal, garden, farmland reconstruction, oil pipeline and other small-scale construction and production field. Adopt Japanese Kubota V2607 engine to meet National 3 emissions standard. The engine features low energy consumption, rapid response, accurate control and small impact, and maintains strong digging force and excellent operating efficiency. By adopting brand new generation of load sensing hydraulic system, the system pressure loss is much less. With three major structural parts upgraded and optimized, it is more reliable and durable. Fully open rear hood and side door, daily maintenance points are within reach.



**Standard Configuration**

	Name of equipment	XE75DA
Engine	Engine model	V2607
	Emission level	Euro3、National3
	Manual preheating	
	Air cleaner (equipped with air cleaner blockage indicator)	
	Double filter element of air filter	
	Air prefilter	
	Collector type engine oil filter	
	Collector type big capacity ash fuel pre-filter	
	Collector type fuel main filter	
	Fan shroud	
	Radiator auxiliary water tank	
	Oil-water separator	
	Electronic fuel speed control	
	55A Alternator	
	60A Alternator	
Hydraulic system	Control valve with main overflow valve	
	Pilot filter	
	Oil suction filter	
	Accumulator	
	Boom/Arm flow regeneration	
Cab and interior trim	Hydraulic oil ISO VG 46	
	Spare valve plate	
	AM - FM radio with digital display	
	All - weather soundproof steel structure cab	
	Ashtray	
	Beverage cup holder	

Cab and interior trim	Two stereo speakers
	Engine key switch
	Emergency hammer
	Fire extinguisher support
	Front window washer
	Cleanable floor mat
	Footrest board
	Mechanical suspension seat with cloth cover
	Openable front upper windshield
	Removable front and lower windshield
	Tempered glass sliding door and window
	Intermittent windscreen wiper
	Seat belt
	Control handle
	Travel control pedal with detachable manual control lever
Safety and security configuration	Coat and hat hook
	High and low gears shift
	Sunshade
	Storage box
	Air conditioning system
	Work aid reservation switch
	Cigarette Lighter/Standby Power Supply
	Top sunroof
	Internal lighting in the cab
	Document bag
Rearview mirror	
LCD liquid crystal monitor	
Driving door locks and cabin locks	

Safety and security configuration	Alarm horn
	Parking brake for walking
	Rotary parking brake
	Isolation plate between engine and pump chamber
	Battery circuit breaker
	Safety rails and pedals
	Dozer retaining valve
	Anti-skid/slip stickers
	Boom, arm holding valve
	Hydraulic safety locking lever
	Emergency escape hammer
	Left and right rearview mirrors
	Front work light
	Roll over protection structure (ROPS)
Counterweight reflector	
Chassis system and shield	Track tensioning mechanism
	Bottom frame traction ring
	450 mm three-rib track shoe
	Bottom sealing plate of chassis
	Walking motor sealing plate
Working device	Track clamp
	Bulldozer shovel
	Supporting chain wheel and supporting wheel
Electrical system	Boom 3.72m
	Arm 1.62m
	Bucket 0.3m <sup>3</sup> (ISO full bucket)
	Battery (1× 120Ah)
	2.5 kW start motor

Electrical system	12V power interface
	Engine cooling water temperature display
	Fuel level display
	Engine speed display
	Working hour meter
	Engine oil pressure, engine overheat alarm
	Charging indication
	Air filter clogging alarm
	Engine warm-up indication
	Hydraulic oil temperature alarm
Lighting lamp	Left boom working light
	Right boom working light
	Working light mounted in the cab
Counterweight	Counterweight
Others	Grease gun stand
	Toolbox

## Optional Configuration

	Name of equipment	XE75DA
Hydraulic system	Hydraulic pipeline: breaking hammer	
	Hydraulic oil ISO VG 32, 68	
Cab and interior trim	Fire extinguisher	
Safety and security configuration	Boom and arm pipe explosion-proof valve	
	Rotating warning light	
	Falling object protection structure (FOPS)	
Chassis system and shield	Track rubber block	
Working device	Bucket 0.18m <sup>3</sup> (Deep groove bucket)	

Working device	Quick connector
	Breaking hammer
	Hydraulic thumb pliers
	Vibrating tamper
	Hydraulic shear
	High efficiency breaker
	Clam shell bucket
Electrical system	Pipe grabber
	12V cigarette lighter

## Main Specifications

Item	unit	Main specifications	
Model	/	XE75DA	
Operating Weight	Kg	7460	
Bucket Capacity	m <sup>3</sup>	0.3	
Engine	Model	V2607-DI-TE3B	
	Direct injection	√	
	Four strokes	√	
	Water cooling	√	
	Turbocharging	√	
	Air-to-air intercooler	√	
	No.of cylinders	4	
	Rated power	kw/rpm	42.4/2000
	Maximum torque/speed	N.m/rpm	222.5/1600
	Displacement	L	2.615
Main Performance	Travel speed(H/L)	km/h	5.4/2.9
	Swing speed	r/min	10
	Gradeability	°	≤35

Item	unit	Main specifications	
Main Performance	Ground pressure	kPa	33.5
	Bucket digging force	kN	57
	Arm digging force	kN	38
	Maximum tractive force	kN	68.3
Hydraulic System	Main pump	/	/
	Rated flow of main pump	L/min	160
	Main safety valve pressure	MPa	26.5
	Travel system pressure	MPa	26.5
	Swing system pressure	MPa	18.6
	Pilot system pressure	MPa	3.5
Oil Capacity	Fuel tank capacity	L	130
	Hydraulic tank capacity	L	76
	Engine oil capacity	L	10
Standard	Length of boom	mm	3720
	Length of arm	mm	1622
	Bucket capacity	m <sup>3</sup>	0.3

## Dimensions

Item	Unit	Parameters
A Overall length	mm	5860
B Overall width	mm	1920
C Overall height	mm	2585
D Width of platform	mm	1780
E Overall width of chassis	mm	1920
F Track shoe width	mm	400
G Wheel gauge	mm	1990
H Track gauge	mm	1500
I Counterweight clearance	mm	700
J Minimum ground clearance	mm	385
Dozer blade (width / height)	mm	1920×340

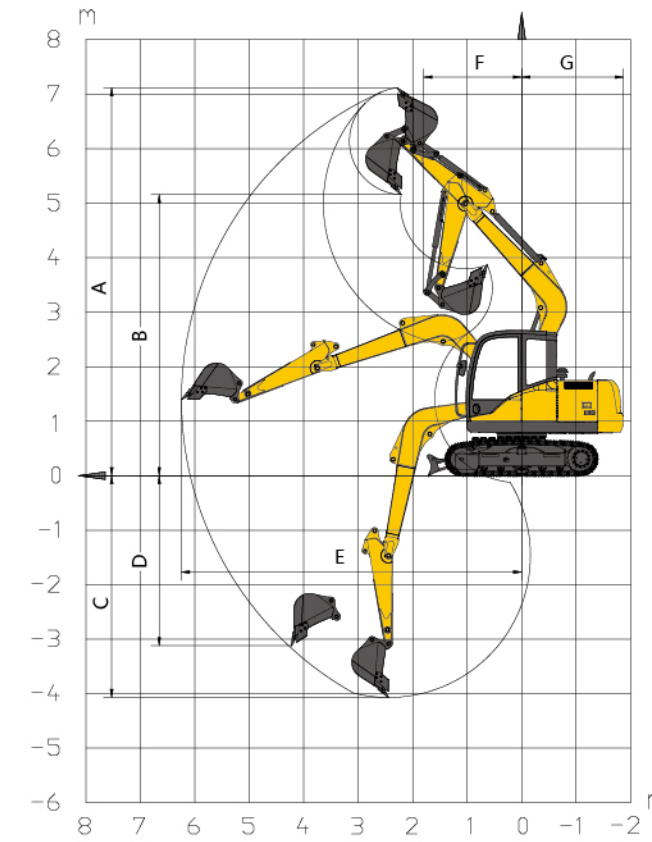
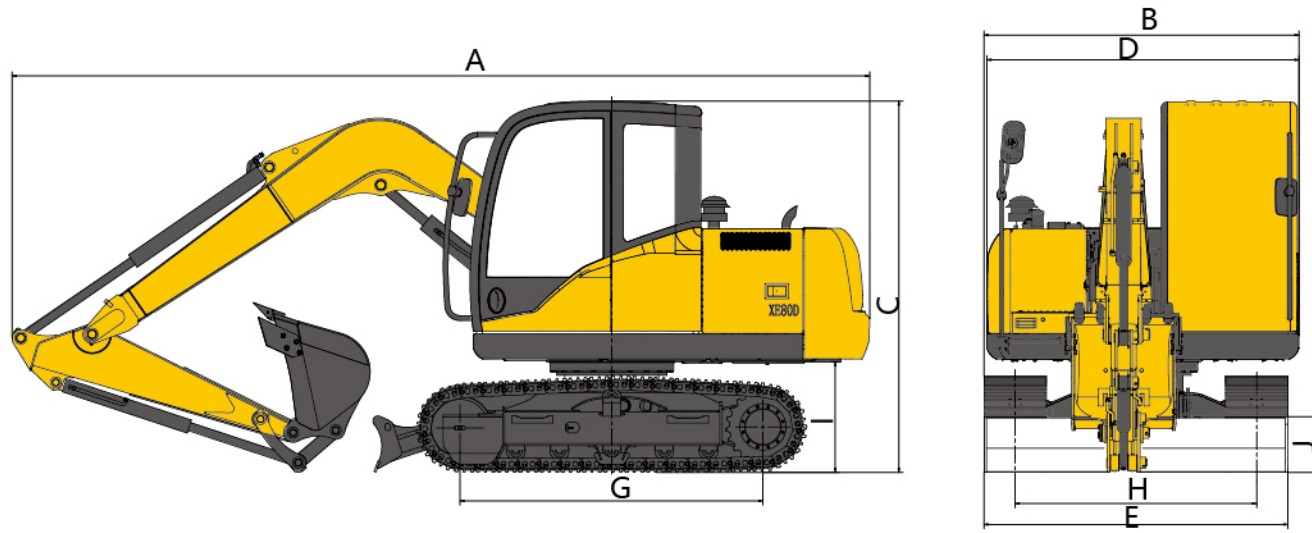

### Working Range

	Item	Unit	Parameters
Working scope	A Max. digging height	mm	7085
	B Max. dumping height	mm	5160
	C Max. digging depth	mm	4020
	D Maximum depth cut for 2240mm(8 ft) level bottom	mm	2920
	E Max. vertical wall digging depth	mm	6260
	F Max. digging radius	mm	1820
	G Min. swing radius	mm	1800
	Max. lifting height of dozer	mm	363
	Max. digging depth of dozer	mm	346

### Lifting capacity

Lifting point height (m)	Rated lift capacity – Straight ahead (back) (kg)					Rated lift capacity – over-side (kg)						
	Lifting point radius (m)					Lifting capacity at maximum radius	Lifting point radius (m)				Lifting capacity at maximum radius	
	1	2	3	4	5		1	2	3	4		5
5			*1613			*1615			*1613			*1615
4			*1795	*1732		*1504			*1795	*1732		*1504
3			*2214	*1911		*1490			*2214	*1911		*1490
2			*2864	*2280	*1923	*1547			*2864	2096	1514	*1547
1			*3312	*2442	*2020	*1653			3129	2040	1489	*1653
Ground			*3513	*2586	*2076	*1874			3071	2001	1471	*1874
-1		*4283	*3460	*2580		*2158		*4283	3056	1987		*2158
-2		*4335	*3110			*2266		*4335	3076			*2266
-3		*15878				*2322		6722				*2322

Capacities marked with an asterisk(\*) are limited by hydraulic capacities.